

PASATIEMPOS DE LECTOESCRITURA



JOSÉ MIGUEL DE LA ROSA SÁNCHEZ

Las actividades propuestas son pasatiempos de sopa de letras, cruzadas y ordenar palabras, en las que la solución se obtiene a partir de gráficos. Estas actividades permiten trabajar, mediante el juego, las palabras usuales que los alumnos/as van aprendiendo en clase.

Una de las principales características de estas actividades es que todas las palabras se forman con las letras que se han estudiado previamente, por ello en la primera ficha tan sólo aparecen palabras con "L" y las vocales, en la siguiente ficha las palabras se forman con la "L", "M" y vocales, y así sucesivamente.

Igualmente el número de gráficos y complejidad (muy básica) va aumentando progresivamente, sin embargo en la sopa de letras, todas la palabra se buscan en horizontal y vertical en sentido de la lectura, no incluyendo en diagonal ni inversas.

Los juegos siguen el orden de las siguientes letras:

L, M, S, P,T,N,D, H, C (ca, co, cu), Q, Ch, G (Ga, Go, Gu), G (Gue, Gui), F, R, J, C (ce, ci), B, Ñ, Y, Z, RR, LI,V, G (Ge, Gi), X, K, Gu (Güe, Güi) y W.

Las imágenes usadas son todas Creative Commons y muchas de ellas de la página de ARASAAC (www.catedu.es/arasaac/). Elaboradas por Sergio Palao para CATEDU con la colaboración de los profesionales del CPEE Alborada (Zaragoza) y la financiación del Departamento de Ciencia, Tecnología y Universidad del Gobierno de Aragón. Los pictogramas contenidos en este catálogo se distribuyen bajo licencia de Creative Commons (BY-NC-SA).



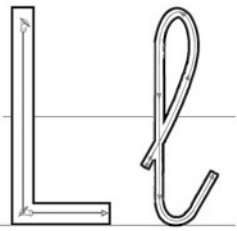

Nombre..... Fecha.....

LA LETRA L

lll

la

le

li

lo

lu

Escribe el nombre de los siguientes dibujos en el crucigrama búscalos en la sopa de letras..

1

2

3

4

5

6

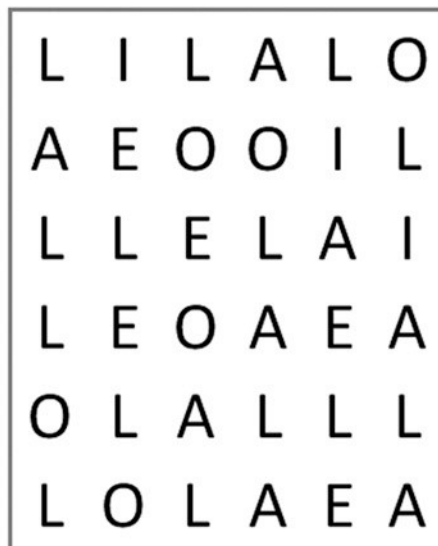
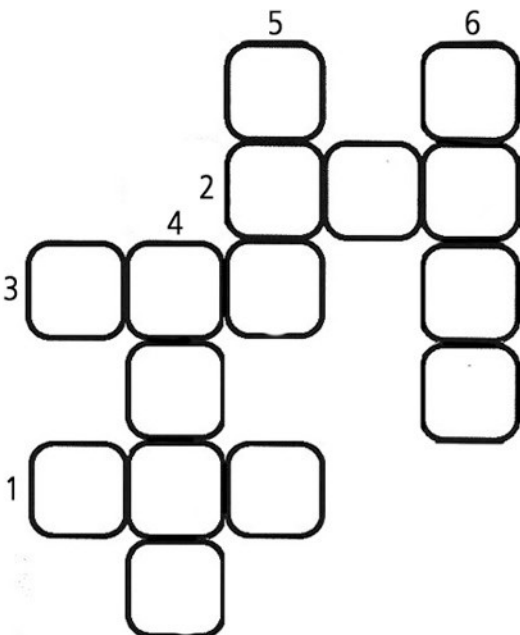
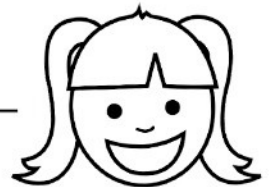
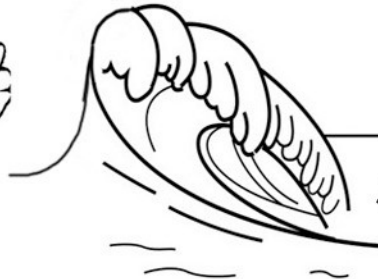

Mm

Nombre..... Fecha.....

LA LETRA m

mmm

ma

mi

mo

mu

me

Escribe el nombre de los siguientes dibujos en el crucigrama buscalos en la sopa de letras.

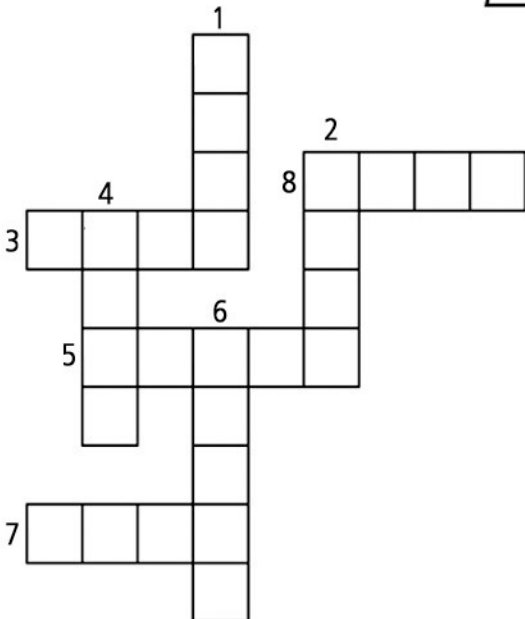
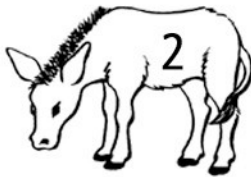

Seis líneas horizontales para escribir las palabras correspondientes a los dibujos.

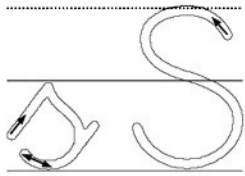

Nombre..... Fecha.....

LA LETRA S

Escribe el nombre de los siguientes dibujos en el crucigrama buscalos en la sopa de letras..

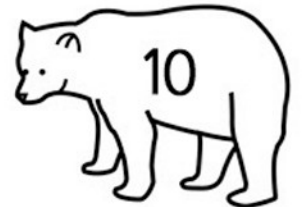
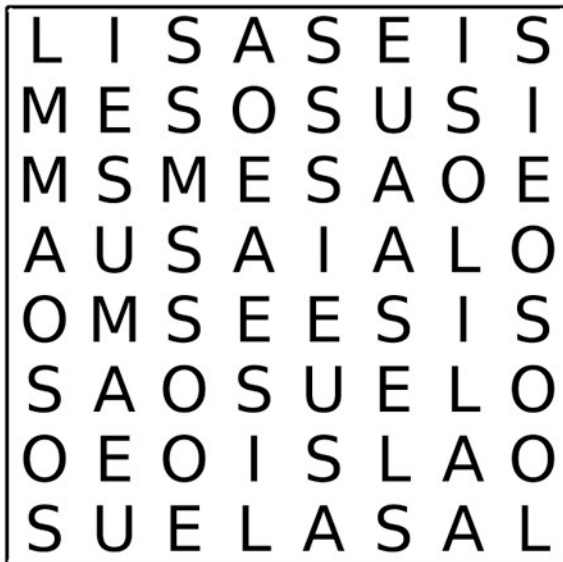
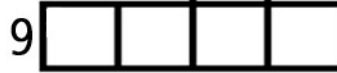
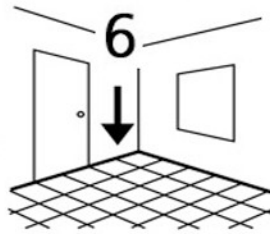
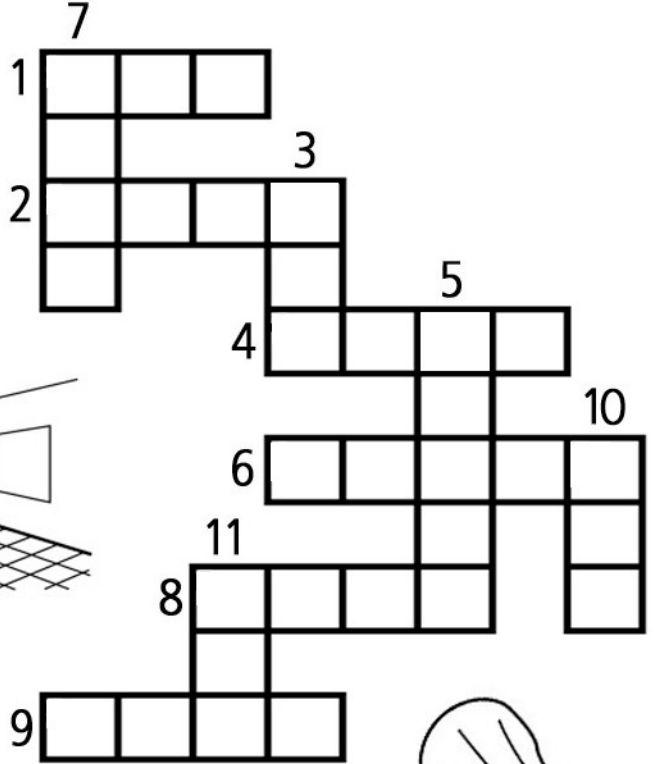

Five horizontal lines for writing the names of the objects found in the word search.

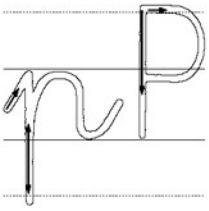

Nombre..... Fecha.....

LA LETRA P

Escribe el nombre de los dibujos numerados en el crucigrama y busca el resto en la sopa de letras. Escríbelos todos al final.

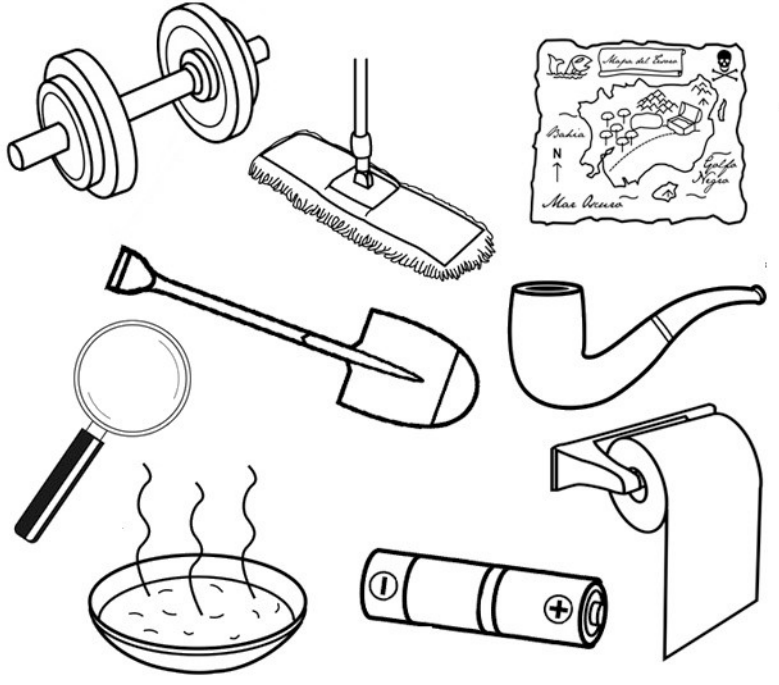
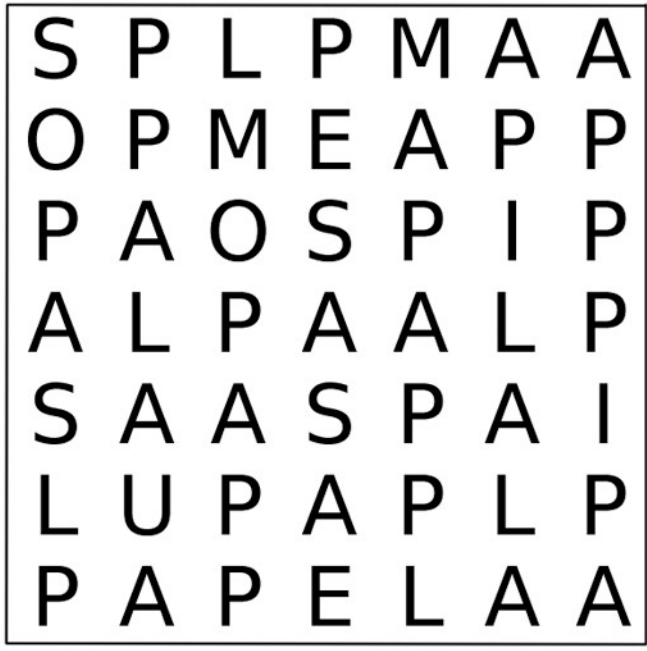
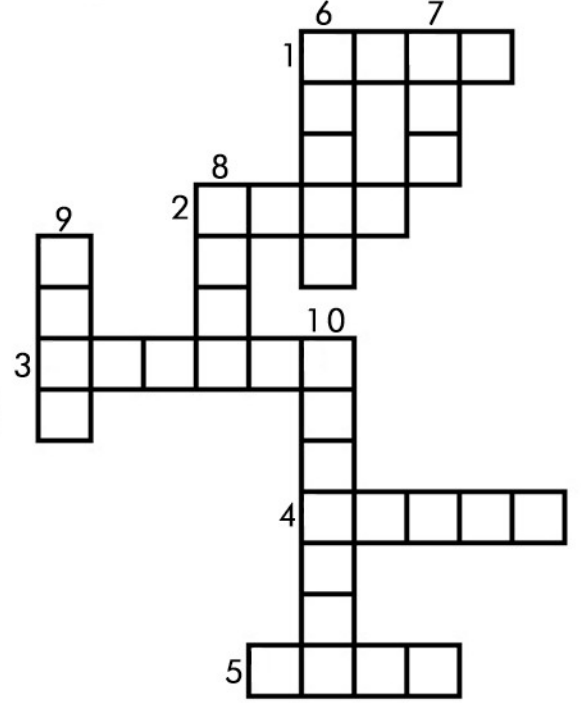

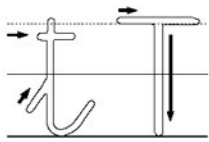

Nombre..... Fecha.....

LA LETRA T

Completa el crucigrama con el nombre de los siguientes dibujos. Los de arriba van en horizontal y los de abajo en vertical. Luego escríbelos abajo.

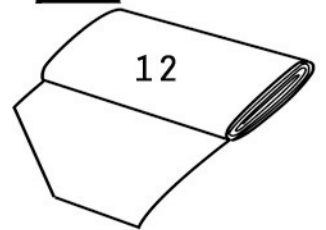
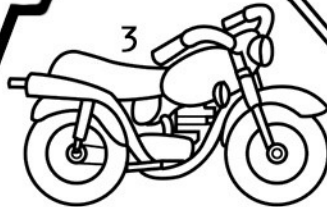
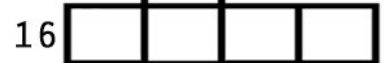
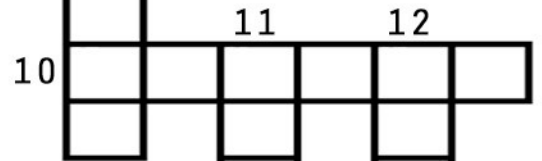
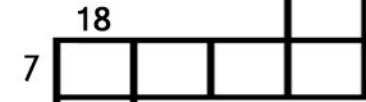
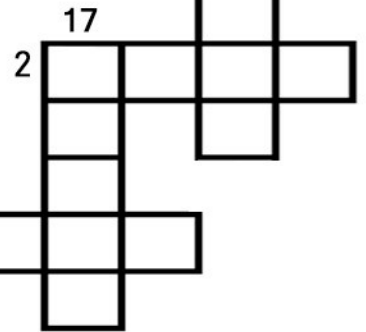
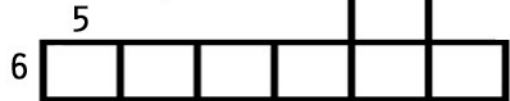
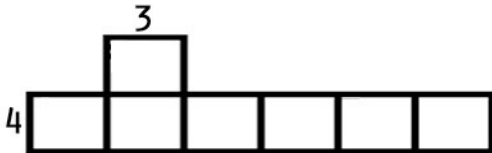
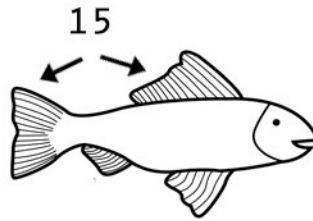
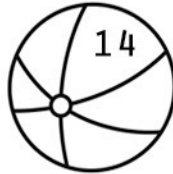
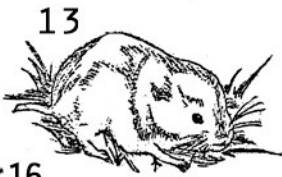
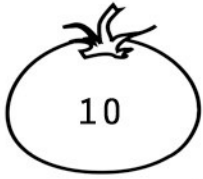
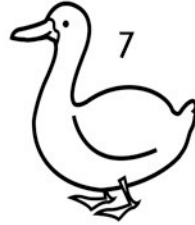
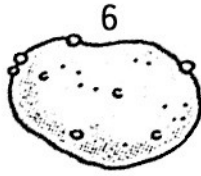
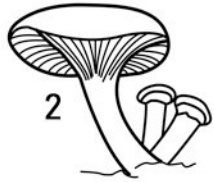

Horizontal lines for writing the names of the objects.



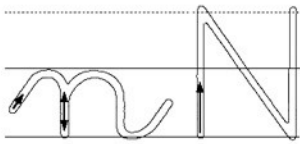

Nombre..... Fecha.....

LA LETRA N

Completa el crucigrama con el nombre de los siguientes dibujos. Los de arriba van en horizontal y los de abajo en vertical. Luego escríbelos abajo.

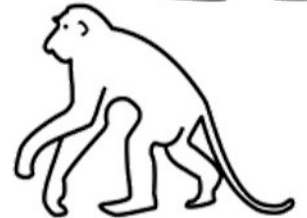
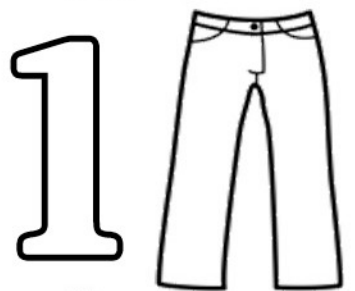
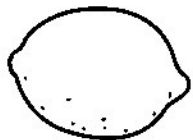
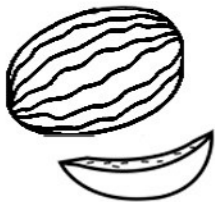
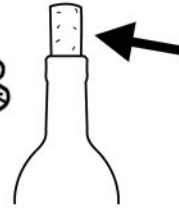
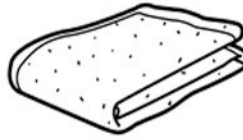
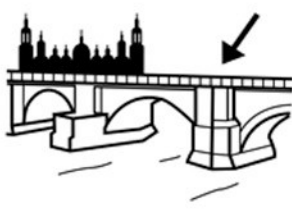

N	M	E	L	Ó	N	N	E	U	N	N
P	A	N	P	U	E	N	T	E	P	A
M	M	P	I	N	O	N	M	N	E	T
O	T	O	A	U	U	E	A	Ó	I	A
L	T	A	P	Ó	N	N	N	A	N	A
I	M	A	N	T	A	E	O	O	E	O
N	E	Ó	P	I	M	I	E	N	T	O
O	L	I	M	Ó	N	M	O	N	O	L
E	L	U	N	A	U	N	O	N	N	E
P	A	N	T	A	L	Ó	N	P	A	Ó
P	I	A	N	O	L	A	N	A	I	N

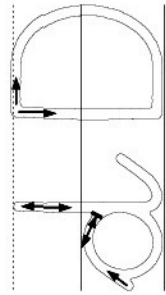

LA LETRA D

Nombre..... Fecha.....

Completa el crucigrama con el nombre de los siguientes dibujos. Luego escríbelos abajo.

LA LETRA H

Nombre..... Fecha.....

Completa el crucigrama con el nombre de los siguientes dibujos. Luego escríbelos abajo.

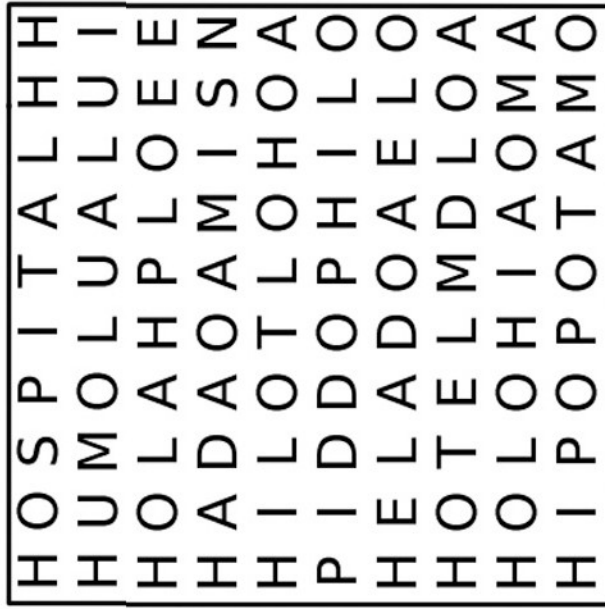
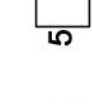
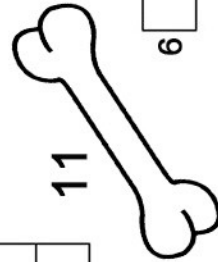
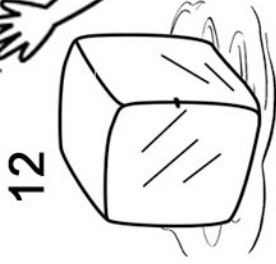
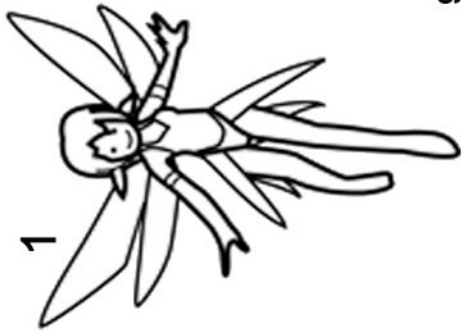
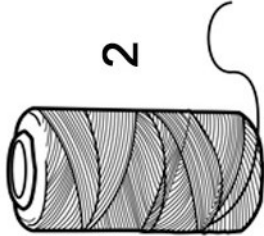
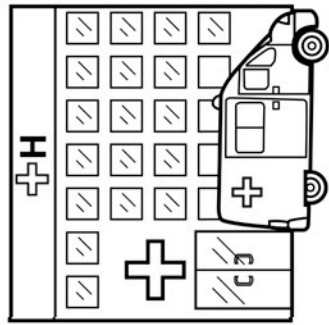
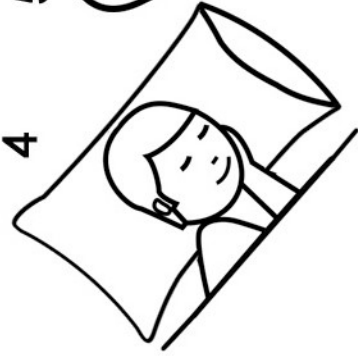
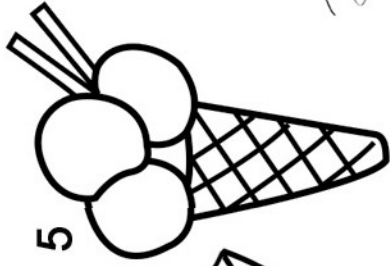
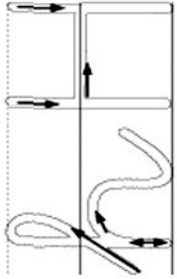

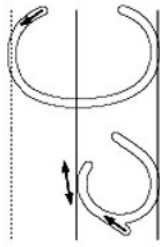

LA LETRA C (ca - co - cu) Nombre..... Fecha.....

Completa el crucigrama con el nombre de los siguientes dibujos. Luego escríbelos abajo.

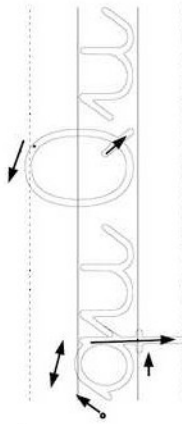

LA LETRA Q

Nombre..... Fecha.....

Completa el crucigrama con el nombre de los siguientes dibujos, búscalas en la sopa de letras y cópialas debajo.

E	S	Q	U	E	L	E	T	O	E	Q	U	I	O	S	C	O	P	A	O
Q	M	A	Q	U	E	S	Q	E	I	M	A	L	P	A	O	L	Q	A	Q
U	I	N	Q	U	E	I	S	T	O	I	T	A	O	S	T	A	O	L	Q
E	S	T	A	N	Q	S	E	I	L	S	A	O	S	T	A	O	L	Q	Q
Q	A	N	Q	U	E	I	S	T	O	I	T	A	O	S	T	A	O	L	Q
U	I	N	Q	U	E	I	S	T	O	I	T	A	O	S	T	A	O	L	Q
E	S	T	A	N	Q	S	E	I	L	S	A	O	S	T	A	O	L	Q	Q

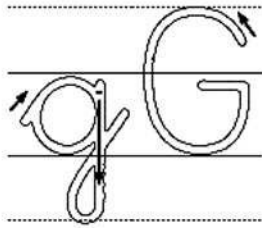

Nombre..... Fecha.....

LA LETRA G (ga, go, gu)

Busca en la sopa de letras el nombre de los dibujos y al final escríbelos debajo

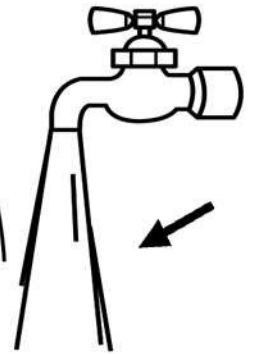
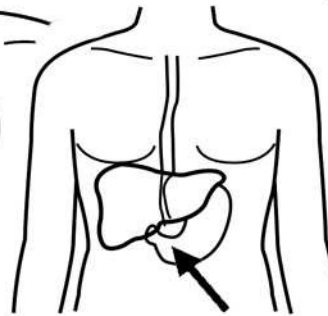
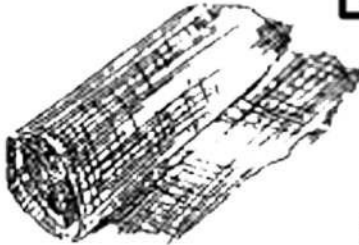
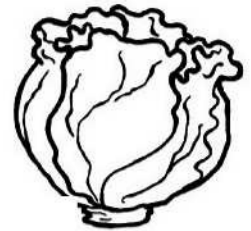
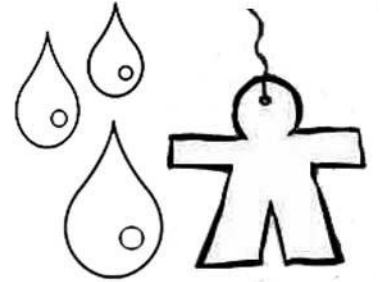
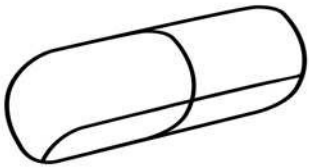
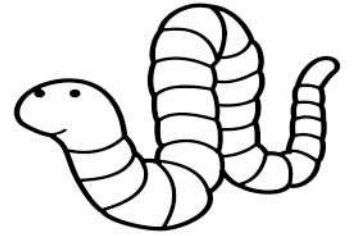
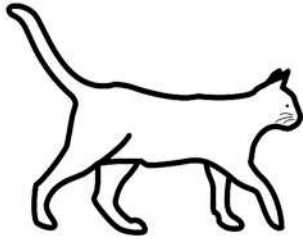
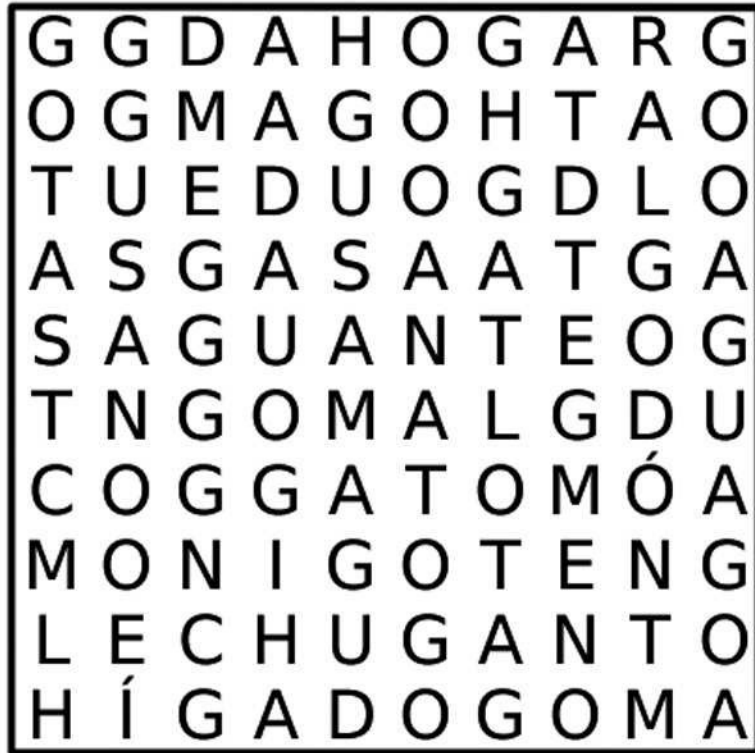

que Qui

Nombre..... Fecha.....

LA LETRA G (que, qui)

Averigua la palabra que esconden las letras desordenadas. Para ayudarte debajo tienes los dibujos de esas palabras, pero ten en cuenta que no están ordenadas.

PISTA: Todas tiene las sílabas "que" o "qui"

ÁGAULI

--	--	--	--	--	--

GIUACHUSOL

--	--	--	--	--	--	--	--	--	--

GOISU

--	--	--	--	--

GIANUD

--	--	--	--	--	--

TUPSASEIEG

--	--	--	--	--	--	--	--	--	--

GAITU

--	--	--	--	--

TUONAMGI

--	--	--	--	--	--	--	--

NSESGUITA

--	--	--	--	--	--	--	--	--	--

GUANÍLA

--	--	--	--	--	--	--	--	--	--

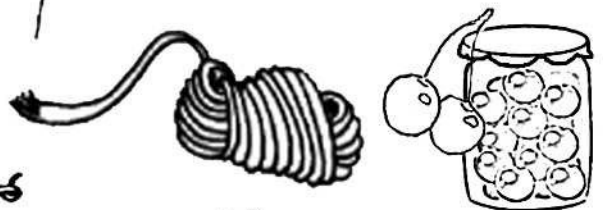
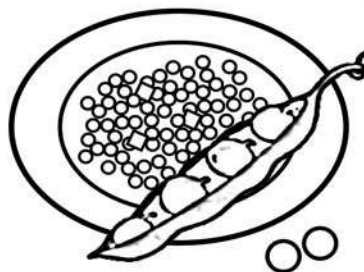
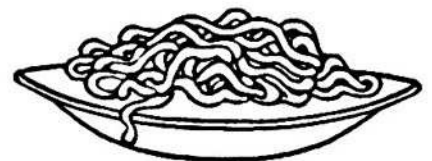
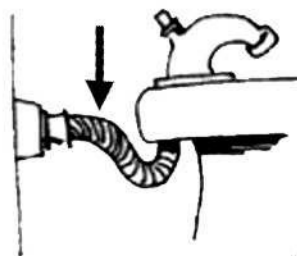
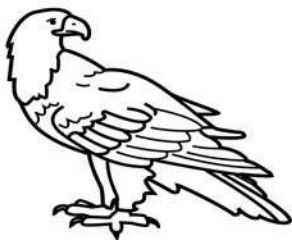

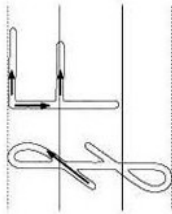

LA LETRA F

Nombre..... Fecha.....

Completa el crucigrama con el nombre de los siguientes dibujos. Luego escríbelos abajo.

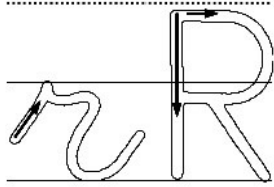

Nombre..... Fecha.....

LA LETRA R

Busca en la sopa de letras el nombre de los dibujos y al final escríbelos debajo

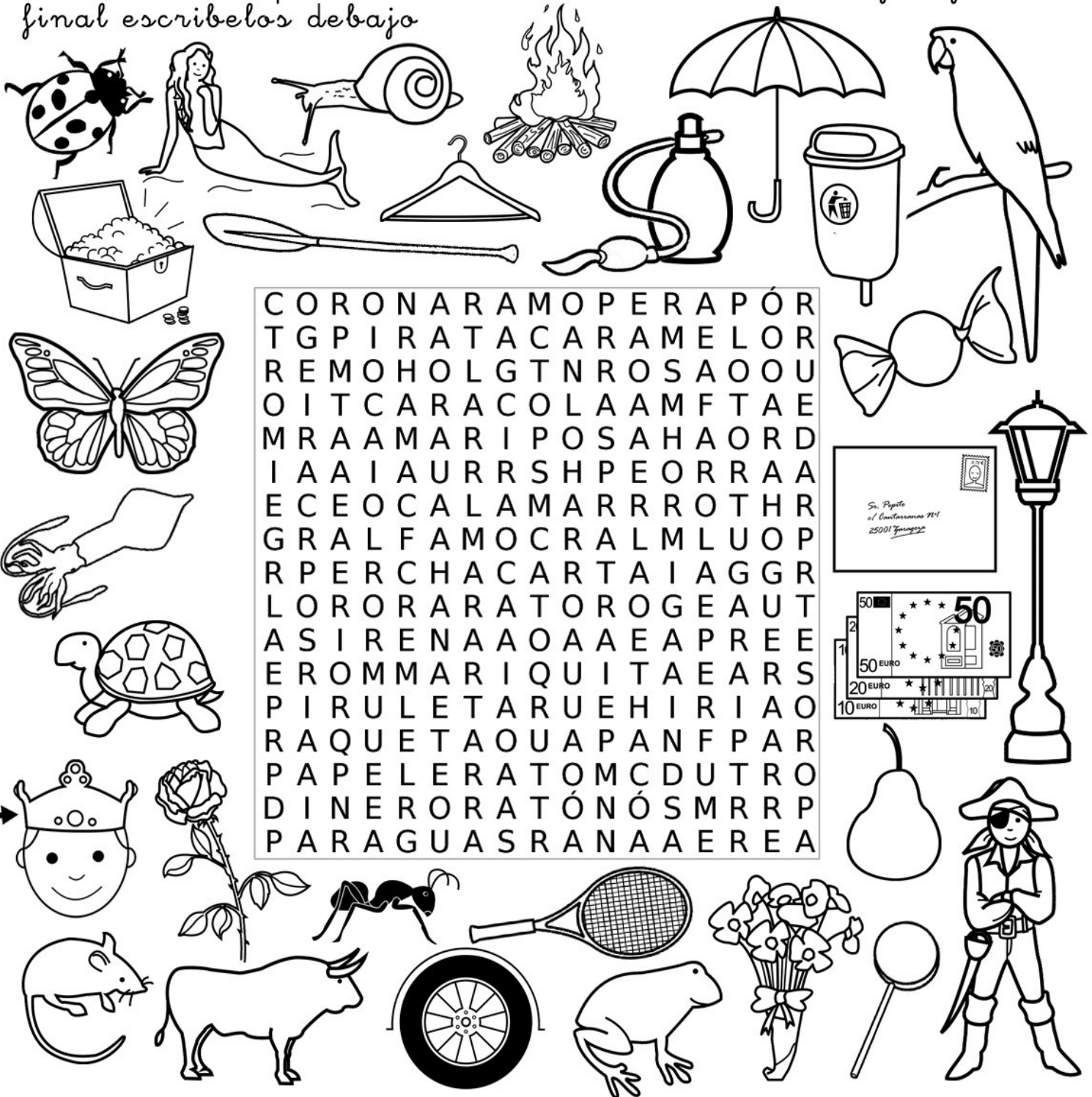

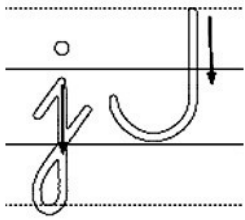

Nombre..... Fecha.....

LA LETRA J

Averigua la palabra que esconden las letras desordenadas. Para ayudarte debajo tienes los dibujos de esas palabras, pero ten en cuenta que no están ordenadas.

TAPESPANAJASOR

--	--	--	--	--	--	--	--	--	--	--	--	--	--	--	--	--	--	--	--

TAJESIR

--	--	--	--	--	--	--	--	--	--

JOLER

--	--	--	--	--	--	--	--

ANJANRA

--	--	--	--	--	--	--	--	--	--

JAHO

--	--	--	--	--	--

RIJAAF

--	--	--	--	--	--	--	--	--	--

JOCENO

--	--	--	--	--	--	--	--

JOPARA

--	--	--	--	--	--	--	--

JESOPE

--	--	--	--	--	--	--	--

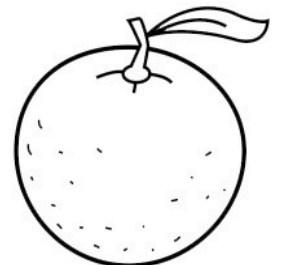
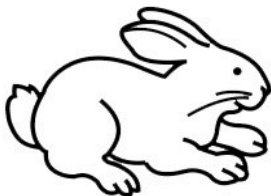
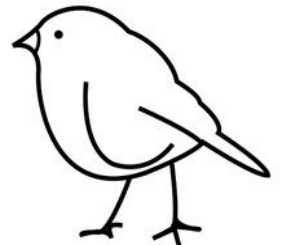

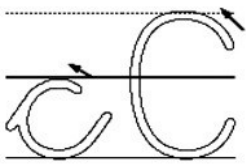

Nombre..... Fecha.....

LA LETRA CE - CI

Busca en la sopa de letras el nombre de los dibujos y al final escríbelos debajo

25 numbered starting points for words in the crossword puzzle:

- 1: Top-left horizontal
- 2: Top-left vertical
- 3: Middle-left vertical
- 4: Middle-left horizontal
- 5: Top-right vertical
- 6: Top-right horizontal
- 7: Middle-left vertical
- 8: Middle-right horizontal
- 9: Middle-left horizontal
- 10: Middle-right horizontal
- 11: Middle-right horizontal
- 12: Middle-right horizontal
- 13: Middle-right horizontal
- 14: Middle-right horizontal
- 15: Middle-right horizontal
- 16: Middle-right horizontal
- 17: Middle-right horizontal
- 18: Middle-right horizontal
- 19: Middle-right horizontal
- 20: Middle-right horizontal
- 21: Middle-right horizontal
- 22: Middle-right horizontal
- 23: Middle-right horizontal
- 24: Middle-right horizontal
- 25: Middle-right horizontal

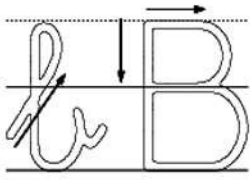

Nombre..... Fecha.....

LA LETRA B

Busca en la sopa de letras el nombre de los dibujos y al final escríbelos debajo



A	B	A	L	O	N	O	O	A	A	S	A	D	B
B	I	B	E	R	O	N	A	B	O	L	S	O	C
U	O	E	S	B	A	R	C	O	B	J	A	O	U
F	N	T	C	G	S	B	B	M	B	A	B	L	B
A	D	O	O	E	I	A	C	B	A	B	E	R	O
N	N	U	B	E	L	B	B	A	I	O	J	B	T
D	T	B	A	R	B	A	S	T	O	N	A	D	O
A	M	B	U	L	A	N	C	I	A	A	A	U	N
A	A	A	T	A	T	I	B	D	B	U	H	O	O
E	N	N	O	B	O	C	O	O	E	N	L	A	A
A	O	D	B	I	G	O	T	E	B	E	O	B	L
O	B	E	U	O	B	O	A	A	E	B	U	A	O
A	O	R	S	S	B	S	S	C	B	N	A	C	A
A	B	A	N	D	E	J	A	B	U	E	L	O	S



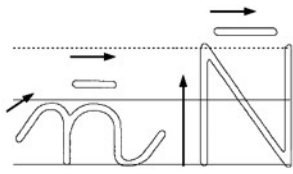

Nombre..... Fecha.....

LA LETRA Ñ

Averigua la palabra que esconden las letras desordenadas. Para ayudarte debajo tienes los dibujos de esas palabras, pero ten en cuenta que no están ordenadas.

AÑARA

--	--	--	--	--

ÑACASTAS

--	--	--	--	--	--	--	--

ÑUSPALOE

--	--	--	--	--	--	--	--	--

ÑAPI

--	--	--	--

ÑABODAR

--	--	--	--	--	--	--	--

RABEÑA

--	--	--	--	--	--	--

ÑUA

--	--	--

MANÑATO

--	--	--	--	--	--	--	--

MAÑECU

--	--	--	--	--	--

DERLOÑA

--	--	--	--	--	--	--	--

ÑALPA

--	--	--	--	--

TUCORAÑAS

--	--	--	--	--	--	--	--	--	--

ÑASTAPES

--	--	--	--	--	--	--	--	--	--

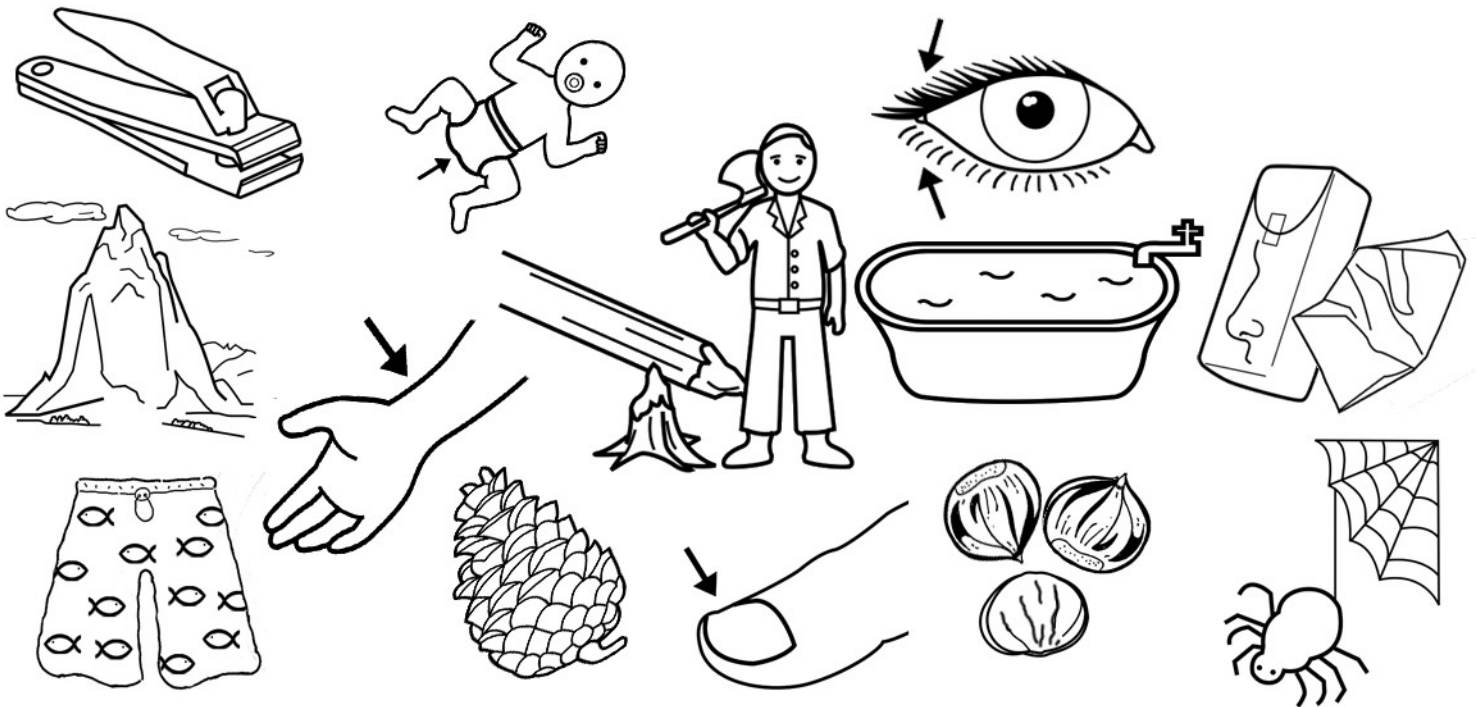

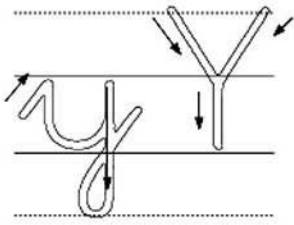

Nombre..... Fecha.....

LA LETRA Y

Busca en la sopa de letras el nombre de los dibujos y al final escríbelos debajo

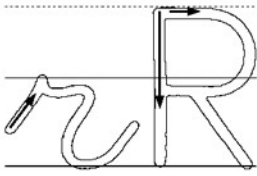

Nombre..... Fecha.....

LETRA RR

Averigua la palabra que esconden las letras desordenadas. Para ayudarte debajo tienes los dibujos de esas palabras, pero ten en cuenta que no están ordenadas.

RRACELLATI

--	--	--	--	--	--	--	--	--	--	--	--

RORBU

--	--	--	--	--

RRIGUATA

--	--	--	--	--	--	--	--	--	--

RORTE

--	--	--	--	--

COSOTARRIS

--	--	--	--	--	--	--	--	--	--	--	--

RRALBI

--	--	--	--	--	--

RERCAR

--	--	--	--	--	--	--

SORRECHU

--	--	--	--	--	--	--	--	--	--	--

TOMORRETE

--	--	--	--	--	--	--	--	--	--	--	--	--

RAJAR

--	--	--	--	--	--

RAGOR

--	--	--	--	--	--

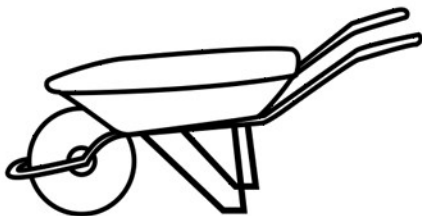
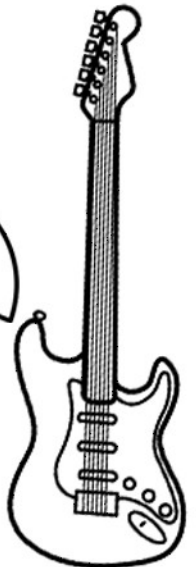
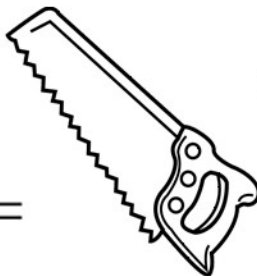
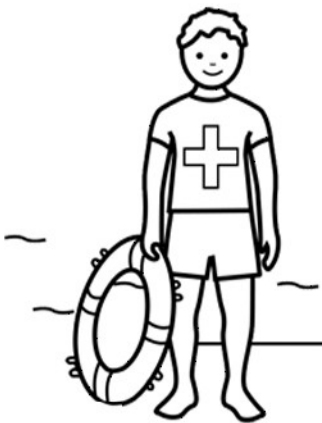

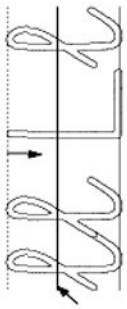

LA LETRA LI

Nombre..... Fecha.....

Completa el crucigrama con el nombre de los siguientes dibujos. Luego escríbelos abajo.

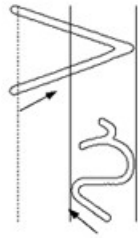

LETRA V

Nombre..... Fecha.....

Busca en la sopa de letras el nombre de los dibujos y al final escríbelos debajo

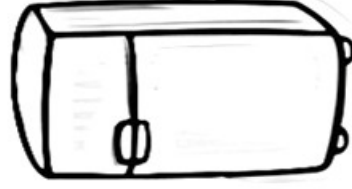
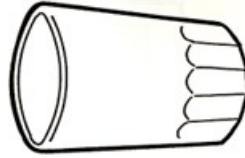
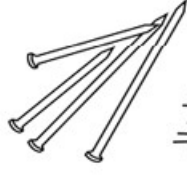
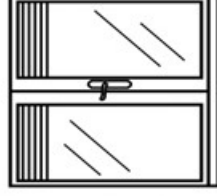
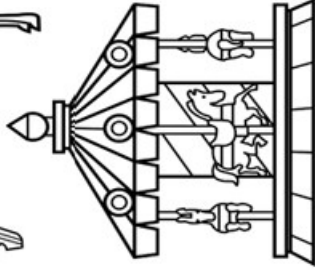
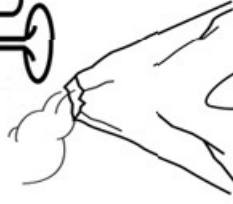
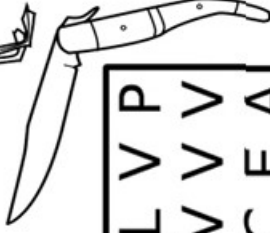
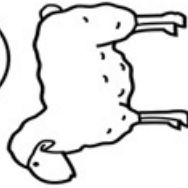
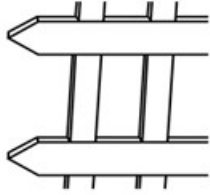
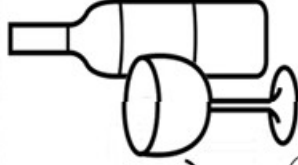
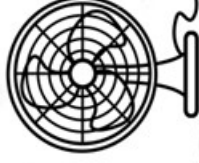
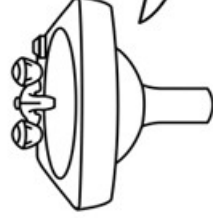
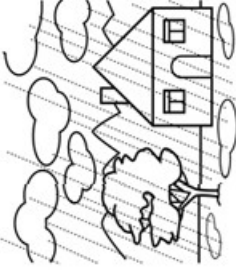
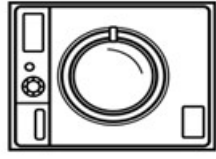
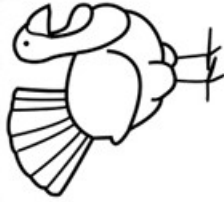
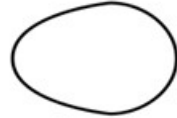

C	U	R	V	O	V	E	J	A	L	V	V	A	L	V	A	L	S	O	P	L	B	O	V	C
V	H	A	V	O	L	A	N	T	E	V	A	M	P	I	S	E	L	T	O	A	I			
H	T	L	V	G	A	V	E	N	T	A	S	I	O	N	E									
C	U	R	V	O	V	E	J	A	L	V	V	A	L	V	A	L	S	O	P	L	B	O	V	C

gegi G e G i

LETRA GE GI

Nombre.....

Fecha.....

Completa el crucigrama con el nombre de los siguientes dibujos. Luego escríbelos abajo.

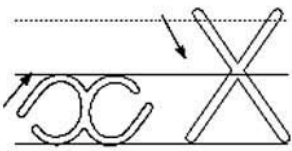

Nombre..... Fecha.....

LA LETRA X

Completa el crucigrama con el nombre de los siguientes dibujos. Los de arriba van en horizontal y los de abajo en vertical. Luego escríbelos abajo.

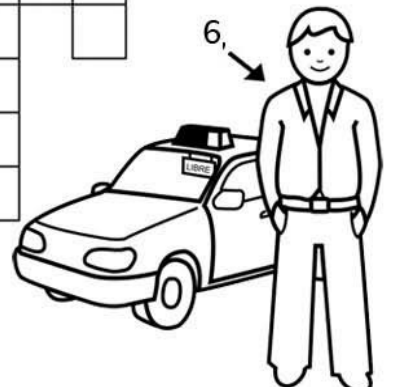
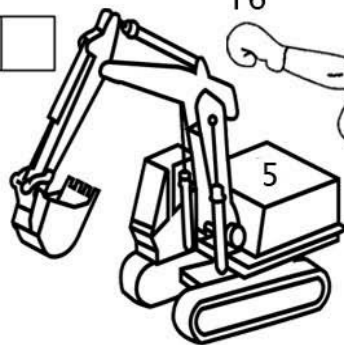
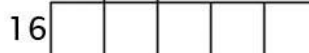
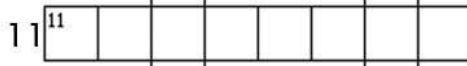
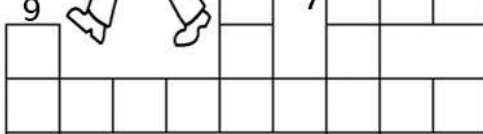
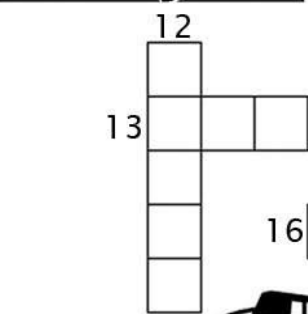
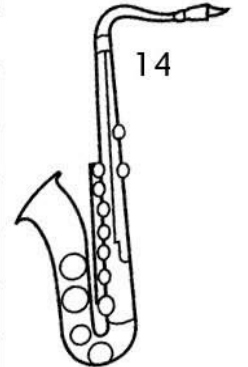
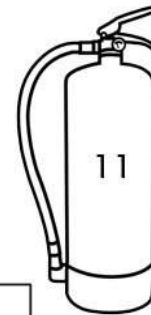
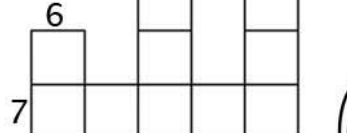
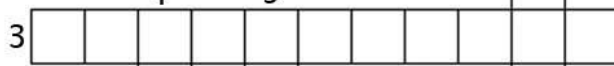
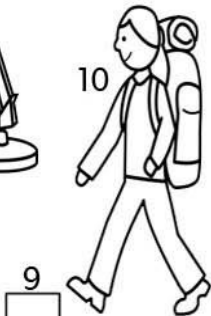
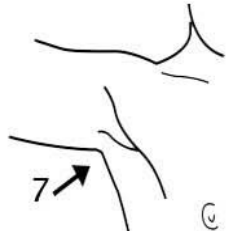
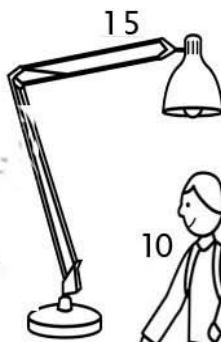
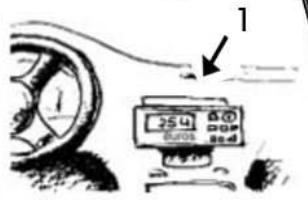
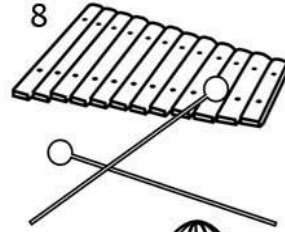
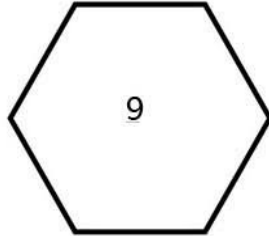

Blank lines for writing the names of the objects.

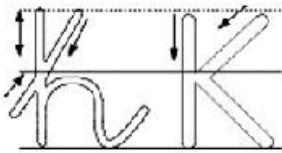

Nombre..... Fecha.....

LA LETRA K

Busca en la sopa de letras el nombre de los dibujos y al final escríbelos debajo

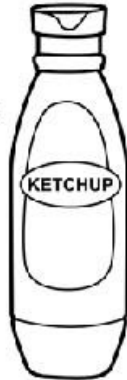
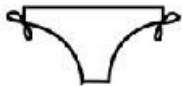
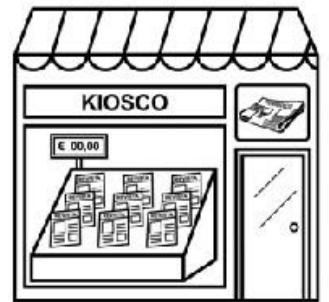
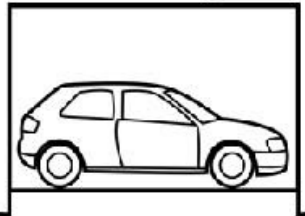

T	O	U	D	M	S	K	N	U	N	K	H	L	T	L	I
A	K	T	D	O	E	G	I	K	K	I	O	S	K	O	A
R	I	T	E	E	J	U	D	O	K	A	C	I	I	O	U
K	I	M	L	U	I	K	A	K	I	N	K	A	M	A	D
T	Y	A	V	S	O	O	S	E	L	O	E	E	O	I	I
E	N	B	I	K	I	N	I	K	O	R	Y	U	N	I	I
Y	K	K	K	A	R	A	T	E	K	A	R	A	O	K	E
K	N	U	I	D	D	A	B	U	I	K	K	K	L	E	
N	D	S	N	I	O	K	M	K	L	N	O	V	M	I	D
P	K	K	G	O	K	K	A	K	O	T	A	A	S	K	K
O	E	I	O	R	K	L	O	R	M	R	D	K	A	K	A
K	T	A	I	K	T	P	O	K	E	R	I	I	O	E	K
C	C	A	O	M	U	E	I	O	T	T	N	O	M	R	L
M	H	E	E	O	K	I	P	A	R	K	I	N	G	I	A
C	U	E	N	T	A	K	I	L	O	M	E	T	R	O	S
K	P	A	K	K	E	R	A	L	L	R	A	O	O	I	



gü Gü

Nombre..... Fecha.....

LETRA "GÜE - GÜI"

Averigua la palabra que esconden las letras desordenadas. Para ayudarte debajo tienes los dibujos de esas palabras, pero ten en cuenta que no están ordenadas.

C A G E Ü Ñ I

--	--	--	--	--	--	--	--

A G T Ü A I

--	--	--	--	--	--	--	--

E D S G A Ü E

--	--	--	--	--	--	--	--

R A R A G Ü E P O

--	--	--	--	--	--	--	--	--	--

D E P I G Ñ Ü E O

--	--	--	--	--	--	--	--	--	--

G Ü I P I N N O

--	--	--	--	--	--	--	--	--	--

Z A R I G Ü E A

--	--	--	--	--	--	--	--	--	--

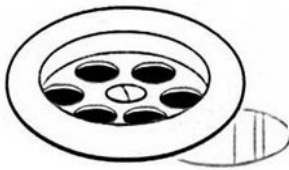

T I R I G Ü A S P A

--	--	--	--	--	--	--	--	--	--

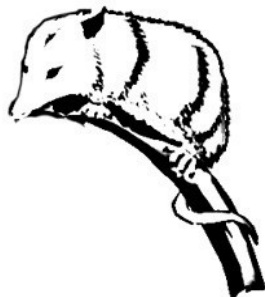
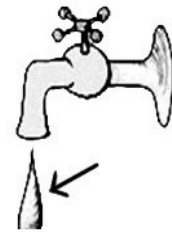

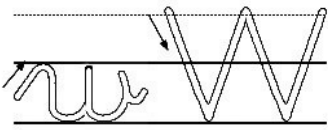

Nombre..... Fecha.....

LETRA W

Averigua la palabra que esconden las letras desordenadas. Para ayudarte debajo tienes los dibujos de esas palabras, pero ten en cuenta que no están ordenadas.

W I K I

4

T E W A R

5

W I S A N C H

7

S U W I N R F

7

T E R P O W A L O

9

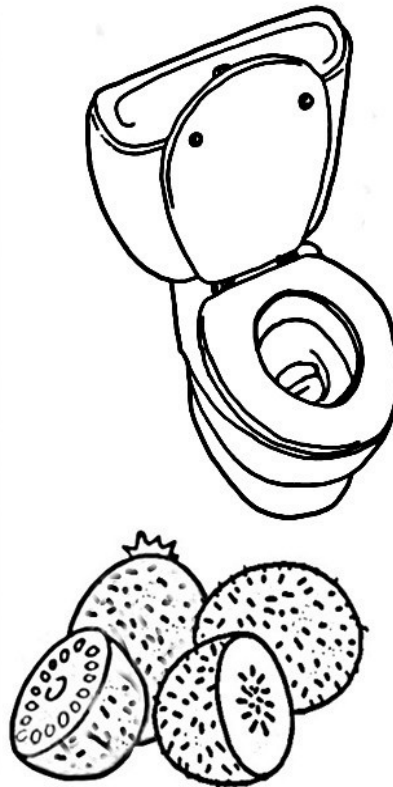
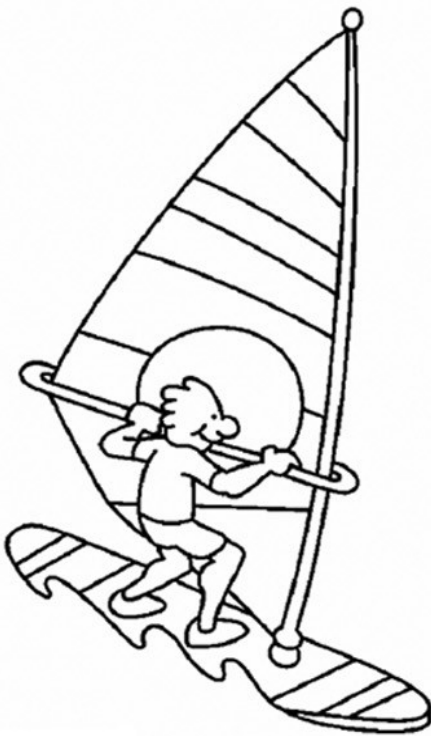

Blank handwriting lines for practice.

